uGreen DAB Board Instructions v11

1 Introduction

The DAB Board v5 is a revised and more efficient new version of the DAB Board. Its small layout allows a better integration into most Raspberry Pi enclosures. It is available in two versions: equipped with a wire antenna or a SMC connector.

Compared to the v3 version, the following features were added:

- I2S full digital audio data transmission to the Raspberry Pi is now supported by the hardware, but a 3rd party driver has to be loaded manually to support it.
- The antenna and L/R audio out are now accessible as pins on the board.
- It is now possible to solder a flash memory chip to the board and have the Si468x load its firmware from that chip. A status LED is now indicating the reset state of the Si468x.
- Silkscreen is printed on the board to show the part numbers.



This document describes

- the DAB Board features
- The pin-out layout
- the software for a terminal based radio.

2 Feature Description

- Silicon Labs Si4684 DAB and FM radio receiver with worldwide FM band support, RDS/RBDS decoder, DAB/DAB+ support and I2S.
- A 3.5 mm audio out to connect headphones or amplifiers.
- The 40 pin connector fits the Raspberry Pi 1 B+, Pi 2 B, Pi 3, Pi 4B and Pi Zero boards. The Si4684 can be programmed using the SPI bus.
- Silicon Labs Firmware is integrated into the terminal software.
- The terminal software for Raspbian and Linux operation systems allows easy remote control of the DAB Board, for example through a ssh connection. It supports automatic station scanning and station list storage and fast station selection and volume control.
- A radio_cli API is provided, which allows simple integration of the Si468x board into Software projects.

3 Electronic configuration

The board is connected to the Raspberry Pi via the SPI bus through pins 19 (MOSI), 21 (MISO), 23 (SCLK) and 24 (chip select). The detailed bus configuration can be found in the Si468x datasheets. It supports up to 10 MHz mode 0 and 3 SPI.

Physical pin 16 is reserved for the RSTB pin of the Si468x and cannot be used for other purposes. If this pin is driven low, the Si468x is reset. If the pin is high, any voltage fluctuations on the power inputs of the Si468x must be avoided, otherwise this can result in permanent damage of the Si468x.

Pin 22 is reserved for the INTB of the Si468x.

Pins 12, 35 and 38 are for the I2S digital audio bus. These pins should be reserved, but might also be used by other boards like the Hifiberry Amp 2 if the Si468x is setup to analog audio output.

Pin description

Table 1 shows a summary of the pin configuration.

Raspberry Pi physical pin	Function	Description
6	GND	Ground
9	GND	Ground
12	DCLK	I2S clock
16	RSTB	Reset button
17	VDD3.3	3.3V Power supply
19	MOSI	SPI master out slave in
21	MISO	SPI master in slave out
22	INTB	Interrupt
23	SCLK	SPI clock
24	SSBSI	Si468x SPI chip select
25	GND	Ground
26	SSBNV	Optional flash SPI chip select
35	DFS	I2S DFS
38	DOUT	I2S data out
39	GND	Ground

Table 1

DAB Board

Pin-out

Drawing 1 shows the pin-out. Pins not listed here are not connected.

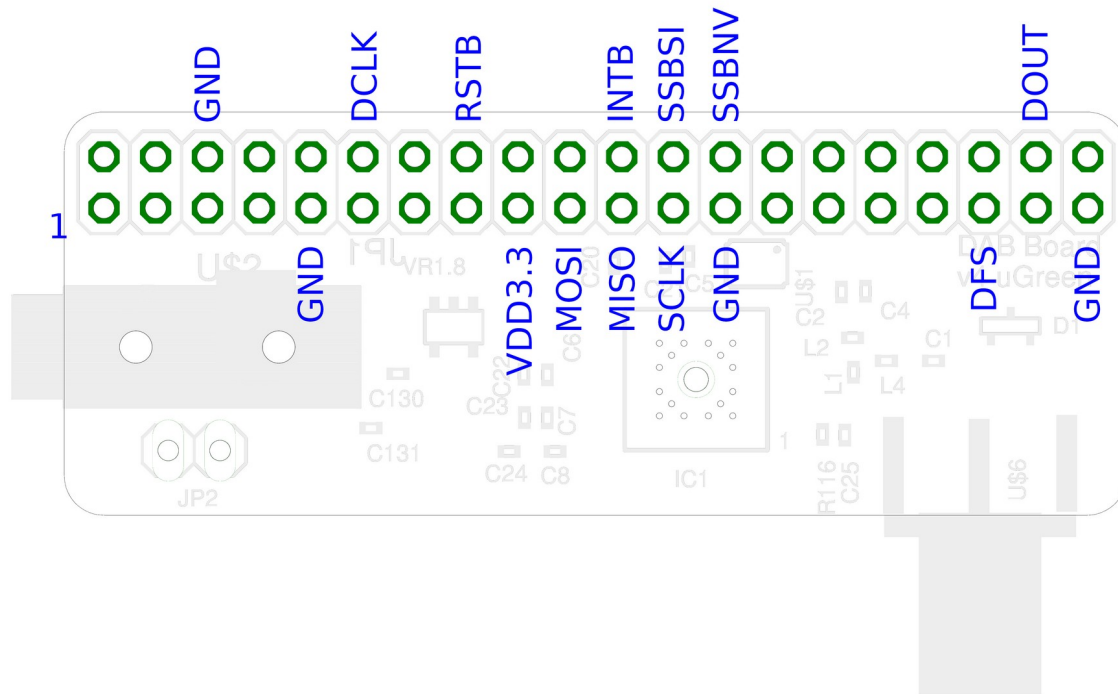

Drawing 1: Board pin-out.

Important Remarks

- The Si468x features a RSTB which needs to be held low while supply voltage levels are not stable. Otherwise, the Si468x can be damaged. This is especially important if an application that holds RSTB high does not terminate correctly, without lowering RSTB again, while the board is unplugged. The new versions of the DAB Board now feature a status LED which indicates the status of the RSTB. If it is alight, the board is running and must not be unplugged.
- The board needs SPI to be enabled: type “`sudo raspi-config`” in a console and choose “Advanced Options” and enable “SPI”. The board not only requires SPI, but also general GPIO ports to set the RSTB pin, therefore any software to access the board needs root privileges.

DAB Board

DC characteristics

Table 2 shows the DC characteristics of the board

Table 2

Parameter	Symbol	Test Condition	Min	Max	Unit
I total	I_T	Separate 5V supply		75.9	mA
P total	P_T	Separate 5V supply		368.9	mW
Supply Voltage 1	$I_{3.3}$		2.7	3.6	V
High Level Input Voltage	V_{IH}		2.3		V
Low Level Input Voltage	V_{IL}			1.0	V
High Level Output Voltage	V_{OH}		2.7		V
Low Level Output Voltage	V_{OL}			0.7	V

Flash Memory

There is the possibility to solder a flash memory to the bottom of the board and to store the Si468x firmware files on the flash. This is possible for example with the Micron M25P16-VMN6P 16 Mbit flash.

DAB Board

Schematic

Drawing 2 shows the board schematic.

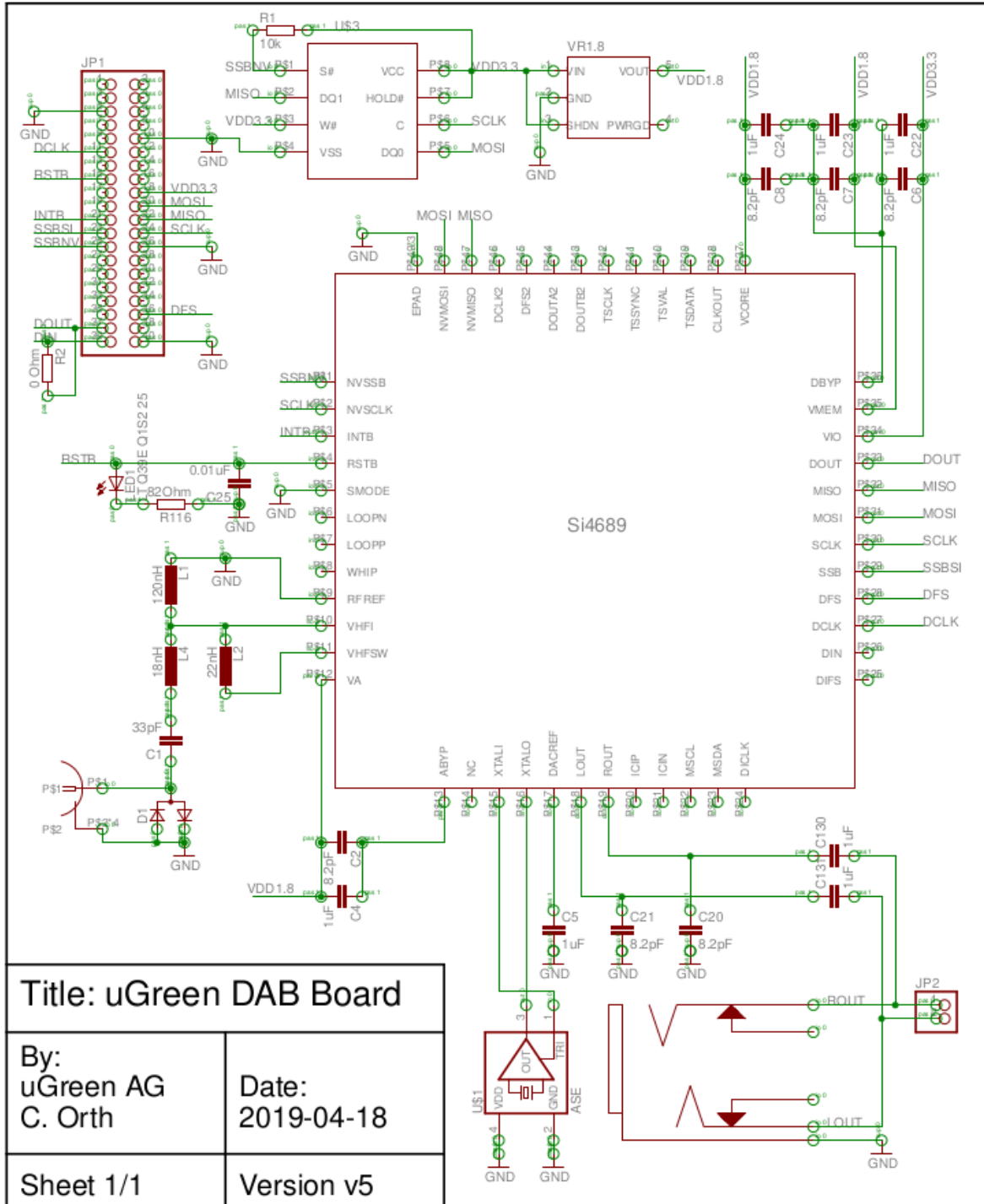

Drawing 2: Board Schematic. Pin 1 on the JP1 connects to Pin 2 on the Raspberry Pi (and the same for the other pins)

4 Software

radio_cli API

The radio client API provides a simple integration of the Si468x into software projects. It allows full control of the Si468x through terminal commands. The SiliconLabs owned firmware is already compiled into the radio client API, which means the user does not have to worry about obtaining a copy of the proprietary firmware files. Simplified boot up and tuning commands are provided as well and data can be exported in .json format for further processing.

The radio client is started using “sudo ./radio_cli” in the terminal. An overview of the available commands can be shown using “sudo ./radio_cli –help”. Drawing 3 shows an overview of the available commands. Most of the command arguments can be combined, this allows boot up, tuning, playing and a change of volume in a single step for example.



```
pi@raspberrypi: ~/radio_cli
File Edit View Search Terminal Help
pi@raspberrypi:~/radio_cli $ ls
ensemblescan_60318 Frankfurt.json radio_cli
pi@raspberrypi:~/radio_cli $ sudo ./radio_cli --help
Starting...radio_cli DAB radio client
radio_cli 1.0.0
Usage: radio_cli [OPTION...]
      Commands and options can be combined. The command: 'sudo
      ./radio_cli -b D -c 12 -e 17333 -f 33 -g -p -l 50' for example will
      boot up with DAB firmware, tune to the frequency with index 33 and
      the service with id 17333 and component id 12, start playing, print
      the service list and adjust the volume to a level of 50.
radio_cli - simple DAB radio interface to the Si468x for the terminal

  -b, --boot=FIRMWARE          Load the firmware and boot the Si468x. Use
                                argument 'D' to load the DAB firmware, 'F' to load
                                the FMHD firmware.
  -c, --component=SERVICE     Component id
  -d, --digrad_status           Prints the digital radio status
  -e, --service=SERVICE       Service id
  -f, --frequency=FREQUENCY    Frequency index of the ensemble
  -g, --digital_service_list    Prints the digital service list of the ensemble,
                                including service data, always as json
  -i, --chip_info               Prints Si468x information
  -j, --format_json             Output info as json, if implemented
  -k, --shutdown               Shut down the Si468x
  -l, --level=LEVEL             Set the volume level of the radio to a value
                                between 0 (low) and 63 (high)
  -n, --event_status            Prints the digital radio event status
  -o, --i2s_out=ENABLE          Enable (i2s_out=1) i2s as output - analog out will
                                be deactivated. To disable, use i2s_out=0. The
                                board must support this and custom kernel needed.
                                The Si468x must not be tuned to change this.
  -p, --play                    Play a station. Service and component have to be
                                given and the Si468x has to be tuned to the right
                                frequency already.
  -r, --rds_status              Print RDS status information
  -t, --datetime                Prints ensemble date-time as ISO string
  -u, --full_scan               Scan all (European) DAB frequencies for ensembles
                                and save to the file "full_scan.json" in json
                                format.
  -x, --next                    Tune to the next FMHD station
  -?, --help                    Give this help list
      --usage                    Give a short usage message
  -V, --version                 Print program version

Mandatory or optional arguments to long options are also mandatory or optional
for any corresponding short options.

Report bugs to <info@ugreen.eu>.
pi@raspberrypi:~/radio_cli $
```

Drawing 3: radio_cli API

DAB Board

Terminal Software

There is a proprietary software available as a terminal program which offers simple radio functionality – upload of the firmware, automated station scanning and station selection. The software can be downloaded from our homepage: <https://ugreen.eu/downloads/>. The software requires the DAB board to be run and is available under proprietary license only. Copy, change and distribution of the software is not allowed, however, the software and any future updates are freely available for customers of the Raspberry Pi DAB Board. If you obtained a copy of the software not directly from uGreen AG, please contact dabboard@ugreen.eu. The Raspberry Pi DAB Board can be run with any other suiting 3rd party software as well.

The software was tested and developed for the Raspbian operating system. On the first start the software will perform an automatic frequency scan which will take up to a minute. After that, the main program will start (see picture) and list all available DAB stations. Use the arrow keys to navigate through the stations, enter to select a station for playing, x to quit, q/w to decrease/increase the volume and ctrl+c to return to the terminal with the radio left on.

The software stores the station list to a file (do not change that), so at the next start, the main program will start automatically and no station scan is performed. To do a station scan again (because the Raspberry Pi was moved to another place with different stations available), select Rescan from the main menu. The stations shown contain also non-audio, pure data stations, such as TPEG services. Playing these do not lead to an audio signal.

The software has to be run with root privileges to allow access to the GPIO pins of the Raspberry Pi. Start of the software is done by “sudo ./DABBoardRadio”. Optionally, a service ID of a station can be given as a command line argument to start the radio and automatically start playing a specific station. The available service IDs can be read off from the stationlist.txt file after a station scan has been performed. To run the radio with a service ID argument, use the command “sudo ./DABBoardRadio -S 12345”, where 12345 is an example of a service ID.

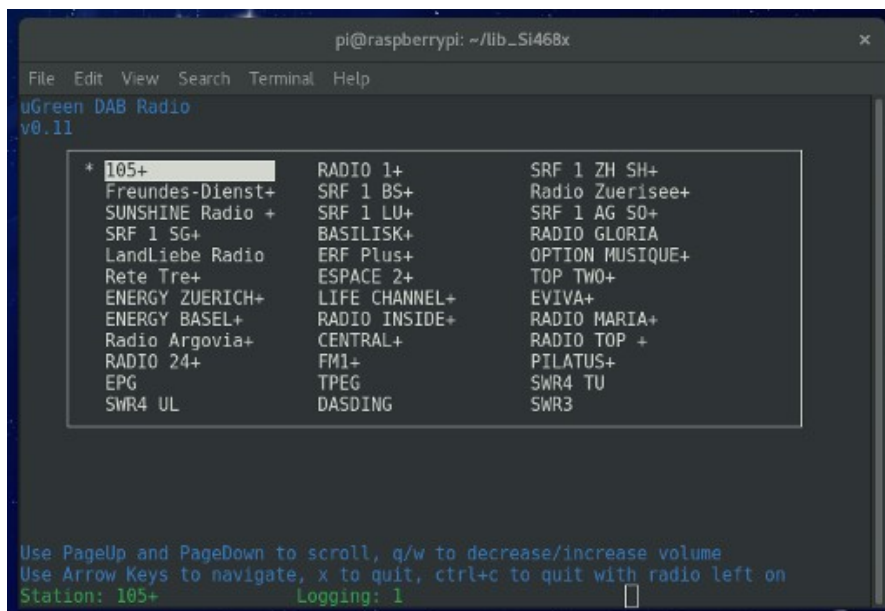

Drawing 4: DABBoardRadio Terminal Program

Getting I2S output to the Raspberry Pi

This part of the datasheet has moved to the website:

<https://ugreen.eu/ugreen-dabboard-i2s/>

5 Board Dimensions

Drawing 5 shows the board dimensions. The 6 mm wide area represents space needed for the SMC connector (not present in the wire antenna version), the 5.5 mm wide area space for the 3.5 mm phone connector.

uGreen DAB Board v4

Dimensions: mm

Board height (empty): 1.6 mm

Board height (populated): 15.4 mm

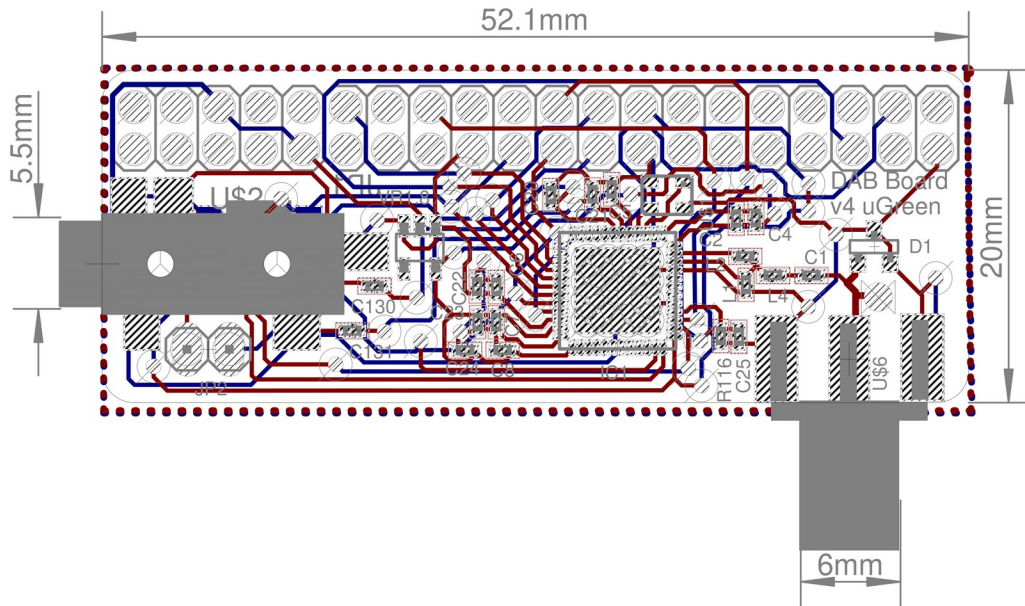

Drawing 5: Board Dimensions

6 FAQ

Please check the FAQ on our website:

<https://ugreen.eu/ugreen-dab-board-faq/>

7 Document Version History

Revision v11

- Moved the I2S section to our website

Revision v10

- Added extra info for long playing (>3h) with arecord

Revision v9

- Extended information about the arecord command line tools to forward the I2S
- Moved FAQ from the instructions pdf to the website.

Revision v8

- Added FAQ section
- Added info to the Pi 4B compatibility

Revision v7

- Added instructions about using an additional amplifier to play the I2S sound
- Comments about the flash memory
- Update of board schematic to meet the v5 layout.

Revision v6

- Added instructions about using the digital I2S output of the board.
- Removed error in the pinout figure.

Revision v5

- Updated the instructions to the new board layout (DABBoard v4)
- Updated figures

Revision v4

- Added introduction to the new terminal client API.

Revision v3

- Adaptation to the new Board v3 Design

Revision v0.12

- Update of product picture.

Revision v0.11

- Added Drawing 4 and board dimensions
- Added DC characteristics

DAB Board

- Added note on the start with station functionality of the software
- Updated function and pin description

Revision v0.1

- Non-production version

8 Contact Information

uGreen AG

c/o Christoph Orth
Schauenburgerstrasse 8
4052 Basel
Switzerland
<http://www.ugreen.eu>
dabboard@ugreen.eu

The information in this document is believed to be accurate in all respects at the time of publication but is subject to change without notice. uGreen assumes no responsibility for errors and omissions, and disclaims responsibility for any consequences resulting from the use of information included herein. Additionally, uGreen assumes no responsibility for the functioning of undescribed features or parameters. uGreen reserves the right to make changes without further notice. uGreen makes no warranty, representation or guarantee regarding the suitability of its products for any particular purpose, nor does uGreen assume any liability arising out of the application or use of any product or circuit, and specifically disclaims any and all liability, including without limitation consequential or incidental damages. uGreen products are not designed, intended, or authorized for use in applications intended to support or sustain life, or for any other application in which the failure of the uGreen product could create a situation where personal injury or death may occur. Should Buyer purchase or use uGreen products for any such unintended or unauthorized application, Buyer shall indemnify and hold uGreen harmless against all claims and damages.